



SPECIFICATION OF LCD MODULE

CUSTOMER 客户名称	
PART NO. 产品型号	OTM732 B-W-1
PRODUCTS TYPE 产品内容	
REMARKS 备注	
SIGNATURE BY CUSTOMER 客户签署:	

		
---	---	---



LCM System

1 LCD Type

S - STN F - FSTN D - DFSTN

2 Viewing Angle

D - Lower 6:00 U - Upper 12:00 O - Others

3 Display Mode

Yellow Green positive Blue Negative Grey positive
 FSTN positive FSTN negative

4 Polarizer Mode

Reflective Transflective Transmissive

5 Connector

Pin Heat sealed Normal

6 Thickness of Glass

1.1mm 0.4mm
 0.55mm 0.7mm

7 Backlight Mode:

LED CCFL

8 Backlight Color

Blue Amber Yellow Green
 Red White Without backlight

9 Temperature Grade

Normal temperature Wide temperature Super wide temperature



•REVISION RECORD

REV. NO.	REV. DATE	DESCRIPTION OF REVISION	PAGE	REMARK
0	04/07/05	INITIAL RELEASE	ALL	



CONTENTS

1.	FEATURES	5
2.	MECHANICAL DATA	5
3.	ABSOLUTE MAXIMUM RATING	6
4.	ELECTRICAL CHARACTERISTICS	6
5.	RELIABILITY	8
6.	BLOCK DIAGRAM	9
7.	TIMIING DIAGRAM	9
8.	AC CHARACTERISTICS.....	10
9.	STANDARD CHARACTER CODE TABLE.....	10
10.	INSTRUCTION SET	11
11.	EXTERNAL DIMENSION	12
12.	INTERFACE.....	13



1. FEATURES

- Display construction..... 240*64 DOTS
- Display mode STN(BLUE)
- Display type Negative Transmissive
- Backlight..... White/5.0V
- Viewing direction..... 6 o'clock
- Operating temperature..... -20 to 70 °C
- Storage temperature -30 to 80°C
- Driving voltage..... Single power
- Driving method..... 1/64 duty, 1/9 bias
- Type..... COB (Chip On Board)
- Drive IC..... T6963C
- Number of data line..... 8-bit parallel
- Connector..... Pin

2. MECHANICAL DATA

ITEM	WIDTH	HEIGHT	THICKNESS	UNIT
Module size	180.0	65.0	12.0(MAX)	mm
Viewing area	132.6	39.0	-	mm
Dot	Size	0.49	0.49	mm
	Pitch	0.53	0.53	mm
Diameter of mounting hole	-			mm
Weight	About 180			g



3. ABSOLUTE MAXIMUM RATINGS

Parameter	Applicable pins	Condition	Rate value	Unit
Power supply voltage	VDD	Ta=25°C	-0.3~7.0	V
Power supply voltage	VIN	Ta=25°C	-0.3~VDD+0.3	V
Operating temperature range	Topr		0~50	°C
Storage temperature range	Tstg		-10~60	°C

4. ELECTRICAL CHARACTERISTICS

Parameter	Applicable pins	Condition	MIN	TY P	MAX	Unit
Power supply voltage	VDD		4.5	5.0	5.5	V
“H” input voltage	VIH		VDD-0.2	-	VDD	V
“L” input voltage	VIL		0	-	0.8	V
“H” output voltage	VOH		VDD-0.3	-	VDD	V
“L” output voltage	VOL		0	-	0.3	V
“H” output resistor	ROH	VOUT=VDD-0.5	-	-	400	Ω
“L” output resistor	ROL	VOUT=0.5V	-	-	400	Ω
Input pull-up resistor	RPU		50	100	200	KΩ
Frequency	Fosc	f=3.0MHz	0.4	-	5.5	MHz
Operating current	IDD(1)	VDD=5.0V	-	3.3	6.0	MA
Static current	IDD(2)	VDD=5.0V	-	-	3.0	UA

4.1 LED ELECTRICAL/OPTICAL CHARACTERISTICS

项目Item	符号 Symbol	最小值 min	典型值 typ	最大值 max	单位 Unit	测定条件 Condition
正向电压 Forward Voltage	V _f	0	3.2	0	V	I _f =100mA
反向电流 Reverse Current	I _r		10		uA	V _r =5V
*亮度 Luminance	L _v		100		cd/m ²	I _f =100mA

4.2 LED ARRAY BLOCK DIAGRAM

(LED DICE 10 dies)

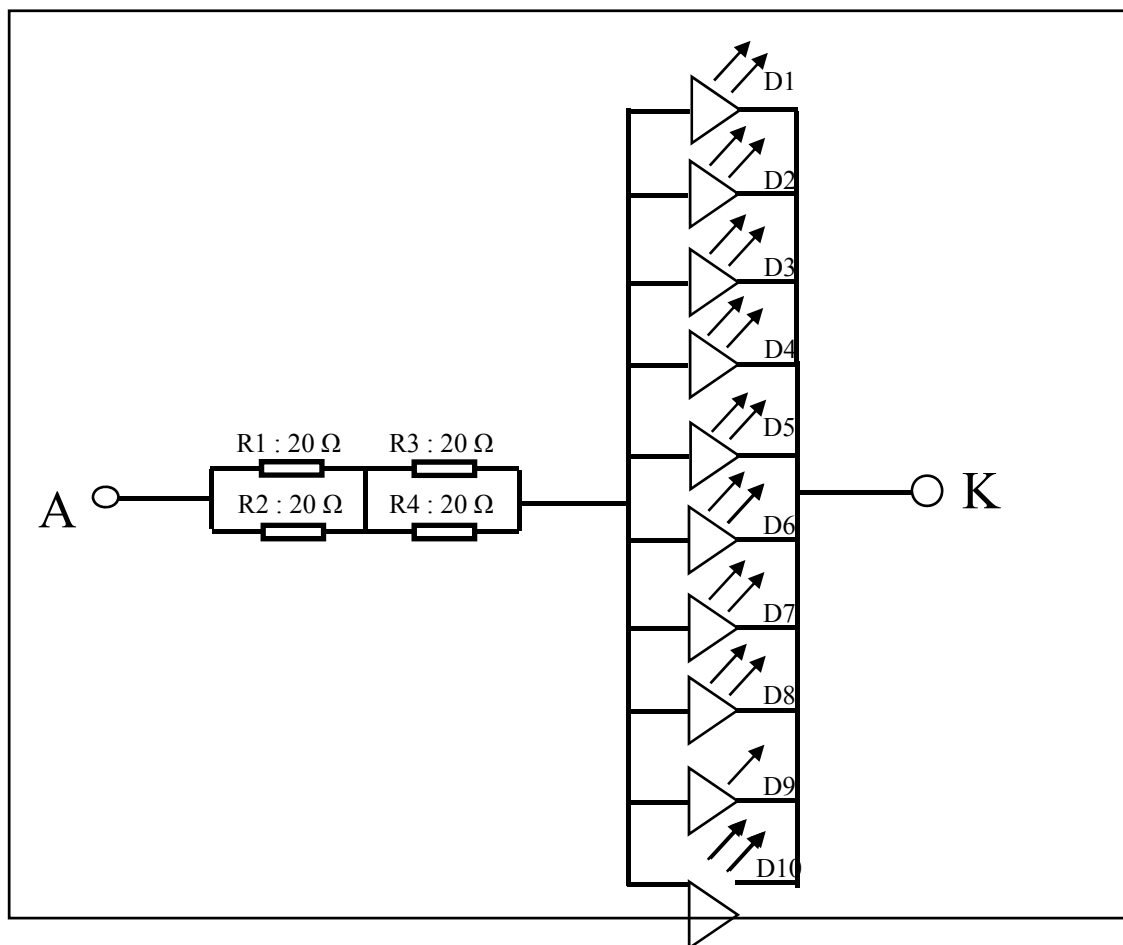



5. RELIABILITY

•Operating life time:

Longer than 50000 hours (at room temperature without direct irradiation of sunlight)

•Reliability Characteristics:

Item	Test	Criterion
High temp	50°C / 200 Hrs	<ul style="list-style-type: none"> ■ Total current consumption should be below double of initial value ■ Contrast ratio should be within initial value ±50% ■ No defect in cosmetic and operational function is allowable
Low temp.	0°C / 200 Hrs	
High humidity	40°C * 90%RH / 200 Hrs	
Thermal shock	0°C→25°C→50°C→25°C /5 Cycles (30min) (5min) (30min) (5min)	
Vibration	1. Operating time: Thirty minutes exposure in each direction (x, y, z) 2. Sweep Frequency (1min): 10Hz→ 55Hz →10Hz 3. Amplitude: 0.75mm double amplitude	

6. BLOCK DIAGRAM

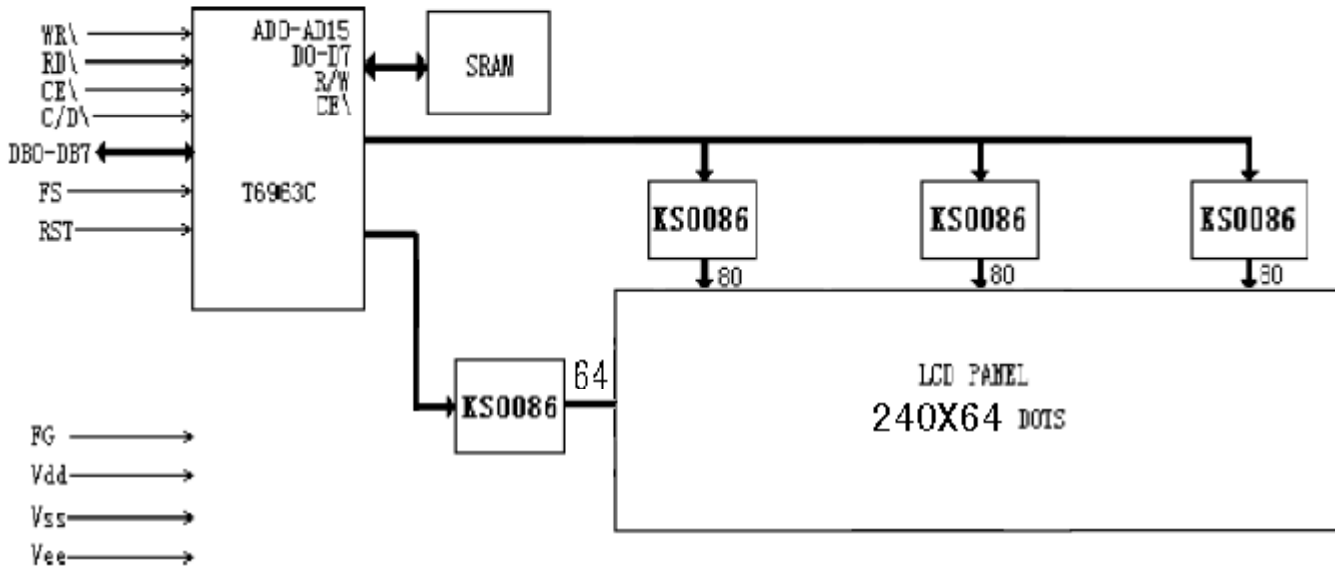

7. TIMING DIAGRAM

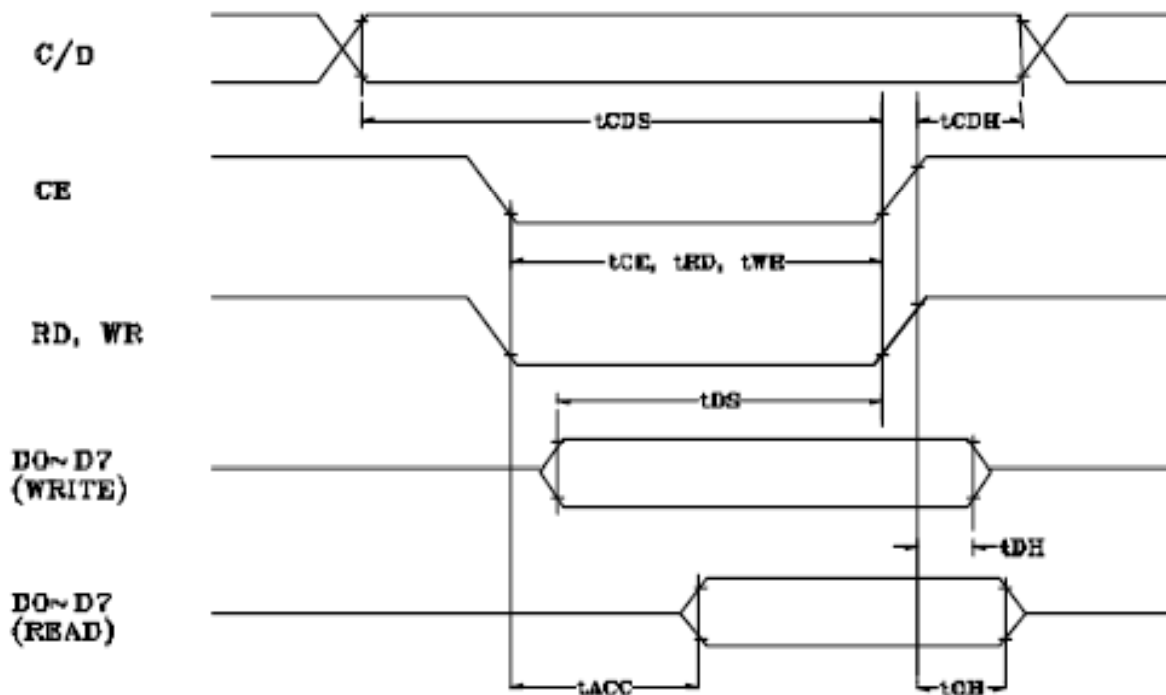

8. AC characteristics

Signal	Symbol	Test Condition	Min.	Max.	Unit
C/D Set Up Time	Tcds		100	--	ns
C/D Hold Time	Tcdh		10	--	
CE, RD, WR Pulse Width	Tce, Trd, Twr		80	--	
Data Set Up Time	Tds		80	--	
Data Hold Time	Tdh		40	--	
Access Time	Tacc		--	150	
Output Hold Time	Toh		10	50	

9. Standard Character Code Table

CHARACTER CODE MAP
The relation between character codes and character pattern(CG TYPE 0101)

LSB MSB	0	1	2	3	4	5	6	7	8	9	A	B	C	D	E	F
0		!	"	#	\$	%	&	'	()	*	+	,	-	.	/
1	0	1	2	3	4	5	6	7	8	9	:	;	<	=	>	?
2	@	A	B	C	D	E	F	G	H	I	J	K	L	M	N	O
3	P	Q	R	S	T	U	V	W	X	Y	Z	[\]	^	_
4	~	a	b	c	d	e	f	g	h	i	j	k	l	m	n	o
5	p	q	r	s	t	u	v	w	x	y	z	{		}	~	
6	ÿ	ü	é	à	á	â	ã	ä	å	ö	è	ë	ê	ì	í	î
7	ë	æ	œ	ø	ù	û	ü	ÿ	ö	ó	ô	õ	ö	ø	æ	œ



10. INSTRUCTION SET

COMMAND	CODE	D1	D2	FUNCTION
REGISTER SET	00100001	X address	Y address	Cursor pointer set
	00100010	Data	00H	offset register set
	00100100	Low address	High address	Address pointer set
CONTROL WORD SET	01000000	Low address	High address	Text home address set
	01000001	Columns	Columns	Text area set
	01000010	Low address	High address	Graphic home address set
	01000011	Columns	Columns	Graphic area set
MODE SET	1000x000	--	--	"OR" mode
	1000x001	--	--	"EXOR" mode
	1000x011	--	--	"AND" mode
	1000x100	--	--	"Text attribute" mode
	10000xxx	--	--	Internal CG ROM mode
	10001xxx	--	--	External CG RAM mode
DISPLAY MODE	10010000	--	--	Display off
	1001xx10	--	--	Cursor on, blink off
	1001xx11	--	--	Cursor on, blink on
	100101xx	--	--	Text on, graphic off
	100110xx	--	--	Text off, graphic on
	100111xx	--	--	Text on, graphic on
CURSOR PATTERN	10100000	--	--	1 line cursor
	10100001	--	--	2 line cursor
	10100010	--	--	3 line cursor
	10100011	--	--	4 line cursor
SELECT	10100100	--	--	5 line cursor
	10100101	--	--	6 line cursor
	10100110	--	--	7 line cursor
	10100111	--	--	8 line cursor
DATA AUTO READ/WRITE	10110000	--	--	Data auto write set
	10110001	--	--	Data auto read set
	10110010	--	--	Auto reset
DATA READ/WRITE	11000000	Data	--	Data write and ADP increment
	11000001	--	--	Data read and ADP increment
	11000010	Data	--	Data write and ADP decrement
	11000011	--	--	Data read and ADP decrement
	11000100	Data	--	Data write and ADP nonvariable
	11000101	--	--	Data read and ADP nonvariable
SCREEN PEEK	11100000	--	--	Screen peek
SCREEN COPY	11101000	--	--	Screen copy

COMMAND	CODE	D1	D2	FUNCTION
BIT SET/RESET	11110xxx	--	--	bit reset
	11111xxx	--	--	bit set
	1111x000	--	--	bit0(LSB)
	1111x001	--	--	bit1
	1111x010	--	--	bit2
	1111x011	--	--	bit3
	1111x100	--	--	bit4
	1111x101	--	--	bit5
	1111x110	--	--	bit6
	1111x111	--	--	bit7(MSB)



11. EXTERNAL DIMENSION

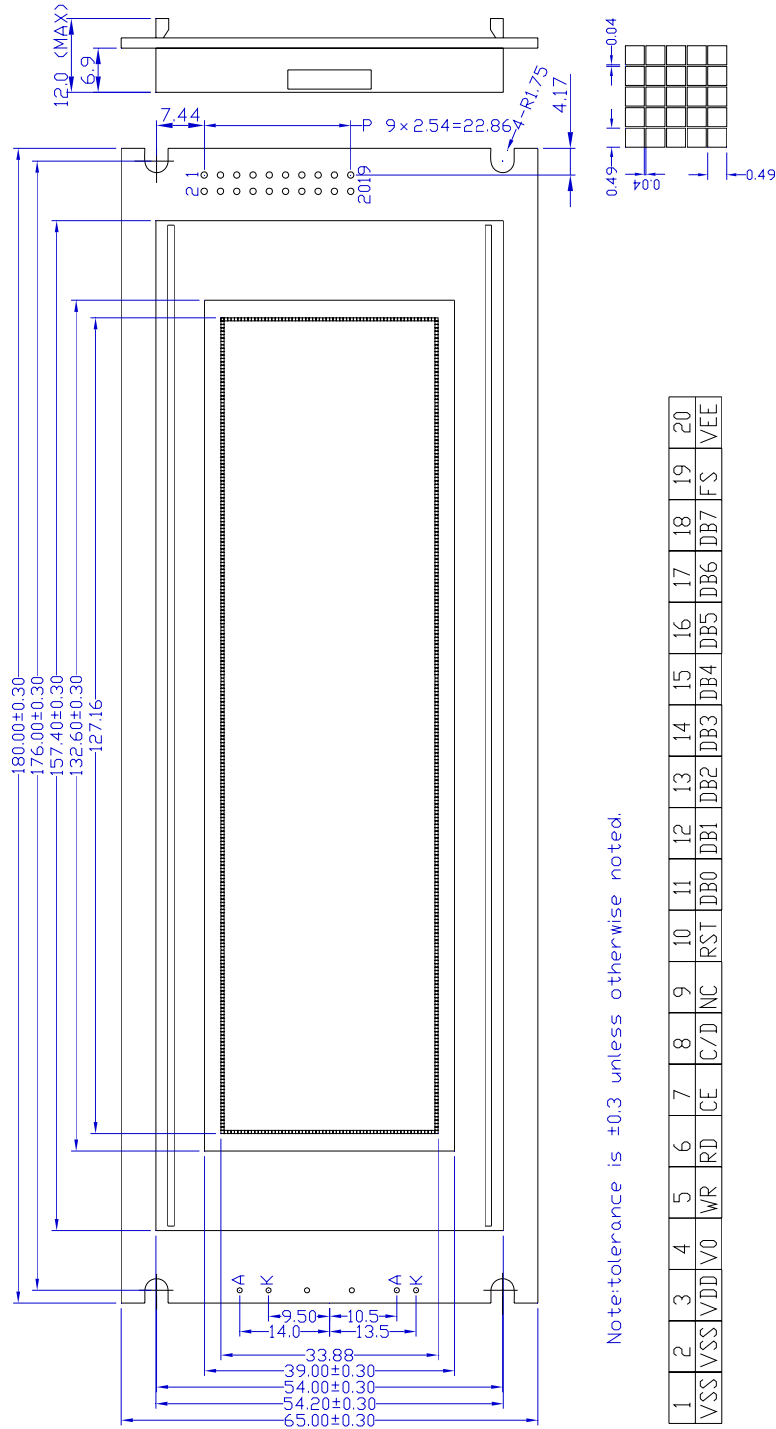

12.INTERFACE

PIN NO.	SYMBOL	DESCRIPTION	FUNCTION
1	VSS	GROUND	0V (GND)
2	VSS	GROUND	0V (GND)
3	VDD	POWER SUPPLY FOR LOGIC CIRCUIT	+5V
4	V0	LCD CONTRAST ADJUSTMENT	
5	WR	WRITE SIGNAL	
6	RD	READ SIGNAL	
7	CE	CHIP SELECTION	CE=0:DATA AND INSTRUCTION ARE AVILABLE
8	C/D	INSTRUCTION/DATA REGISTER SELECTION	C/D=1:INSTRUCTION REGISTER C/D=0:DATA REGISTER
9	NC		
10	RST	RESET SIGNAL	RST=0,DISPLAY OFF
11	DB0	DATA INPUT/OUTPUT LINES	8 BIT: DB0-DB7
12	DB1		
13	DB2		
14	DB3		
15	DB4		
16	DB5		
17	DB6		
18	DB7		
19	FS	FONT SELECTION	FS=0:8x8 FS=1:6x8
20	VEE	NEGATIVE VOLTAGE	-10V