

## SPECIFICATION OF LCD MODULE

<b>CUSTOMER</b> 客户名称	
<b>PART NO.</b> 产品型号	<b>OTM732 Y-YG-1</b>
<b>PRODUCTS TYPE</b> 产品内容	
<b>REMARKS</b> 备注	
<b>SIGNATURE BY CUSTOMER</b> 客户签署:	

		
---	---	--

Optima EnC Co., Ltd

Tel ; 02-2612-4767

Fax; 02-6679-4767

## LCM System

1 LCD Type

S - STN

F - FSTN

D - DFSTN

2 Viewing Angle

D - Lower 6:00

U - Upper 12:00

O - Others

3 Display Mode

Yellow Green positive

Blue Negative

Gray positive

FSTN positive

W - FSTN negative

4 Polarizer Mode

Reflective

Transflective

Transmissive

5 Connector

Pin

Heat sealed

Zebra

6 Thickness of Glass

1.1mm

0.4mm

0.55mm

0.7mm

7 Backlight Mode:

LED

CCFL

8 Backlight Color

Blue

Amber

Yellow Green

Red

White

Without backlight

9 Temperature Grade

Normal temperature

Wide temperature

Super wide temperature



# CONTENTS

1.	FEATURES .....	5
2.	MECHANICAL DATA .....	5
3.	ABSOLUTE MAXIMUM RATING .....	6
4.	ELECTRICAL CHARACTERISTICS .....	8
5.	ELECTRO-OPTICAL CHARACTERISTICS .....	10
6.	BLOCK DIAGRAM .....	11
7.	POWER SUPPLY .....	11
8.	TIMIING DIAGRAM .....	12
9.	INITIALIZATION SET .....	14
10.	STANDARD CHARACTER CODE TABLE .....	15
11.	QUALITY ASSURANCE.....	15
12.	OUTLINE DRAWING .....	17
13.	INTERFACE .....	18
14.	PACKAGE INFORMATION.....	19
15.	QC/QA PROCEDURE .....	20
16.	HANDING PRECAUTIONS.....	21

Y-**1. FEATURES**

- Display construction..... 240\*64 DOTS
- Display mode ..... STN(Y/G)
- Display type ..... Positive Transmissive
- Backlight..... LED ( Y/G ) /5.0V
- Viewing direction..... 6 o'clock
- Operating temperature..... -20 to 70 °C
- Storage temperature ..... -30 to 80°C
- Driving voltage..... Single power
- Driving method..... 1/64 duty, 1/9 bias
- Type..... COB (Chip On Board)
- Drive IC..... T6963C
- Number of data line..... 8-bit parallel
- Connector..... Pin

**2. MECHANICAL DATA**

ITEM	WIDTH	HEIGHT	THICKNESS	UNIT
Module size	180.0	65.0	12.0(MAX)	mm
Viewing area	132.6	39.0	-	mm
Dot	Size	0.49	0.49	mm
	Pitch	0.53	0.53	mm
Diameter of mounting hole	R1.75			mm
Weight	About 200			g

## 3. ABSOLUTE MAXIMUM RATINGS

### 3.1 Electrical Absolute Maximum Rating

(TA = 25 , Vss=0V)

Item	Symbol	MIN.	Max.	Unit
Supply Voltage (Logic)	VDD-VSS	0	7.0	V
Supply Voltage (LCD Driver)	V <sub>EE</sub>	V <sub>DD</sub> -19.0	V <sub>DD</sub> +0.3	v
	V <sub>LCD</sub>	V <sub>EE</sub> -0.3	V <sub>DD</sub> +0.3	V
Input Voltage	V <sub>IN</sub>	-0.3	VDD+0.3	V
Operating temperature	Top	-20	70	°C
Storage temperature	Tsto	-30	80	°C

### 3.2 Environmental Absolute Maximum Rating

Item	Operating		Storage		Comment
	Min.	Max.	Min.	Max.	
Ambient temp	-20	+70	-30	+80	Note(1)
Humidity	Note(2)		Note(2)		Without condensation
Vibration	--	4.9M/S <sup>2</sup>	--	19.6M/S <sup>2</sup>	XYZ direction
Shock	--	29.4M/S <sup>2</sup>	--	490M/S <sup>2</sup>	XYX direction

Note(1) Ta=0°C: 50 Hr Max.

Note(2) Ta≤40°C: 90%RH Max.

Ta≥40°C: Absolue humidity must be lower than the humidity of 90%RH@40°C

### 3.3 Electronic Static Discharge Maximum Rating

#### ESD Test Method : IEC-1000-4-2

Item	Description	
Testing environment	Ambient temperature : 15°C to 35°C Humidity : 30% to 60% LCM(E.U.T) : Power up	
Testing equipment	Manufacture : Noiseken, Model No. ESD	
Testing condition	See drawing 1	
Direct discharge	0 to $\pm 4$ KV	Discharge point, see drawing2
Indirect discharge	0 to $\pm 8$ KV	Discharge point, see drawing1
Pass condition	No malfunction of unit. Temporary malfunction of unit which can be recovered by system reset.	
Fail condition	Non. Recoverable malfunction of LCM or system.	

#### FIG1 ESD Testing Equipment

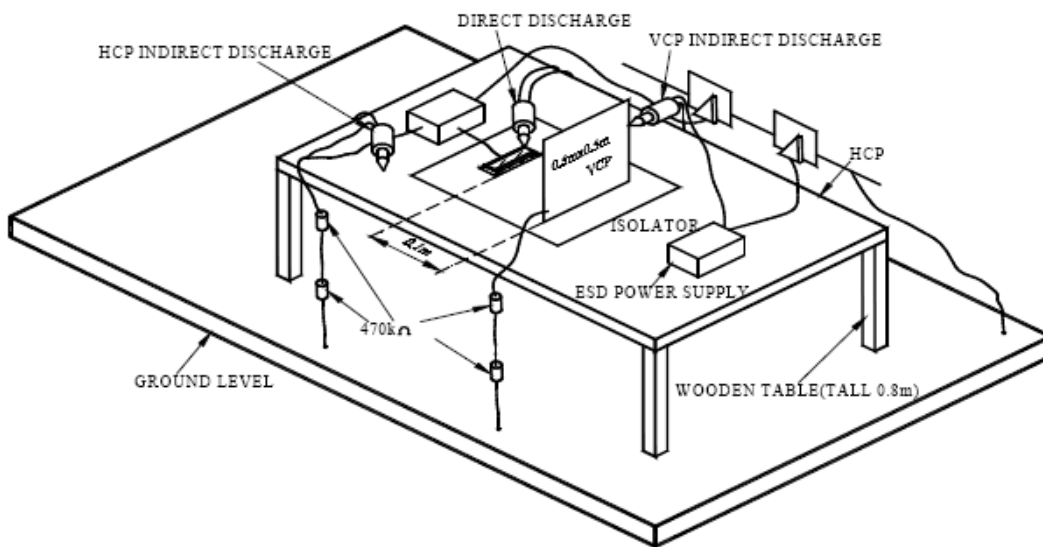

#### Direct Contact Discharge / Contact Point : A,B,C,D

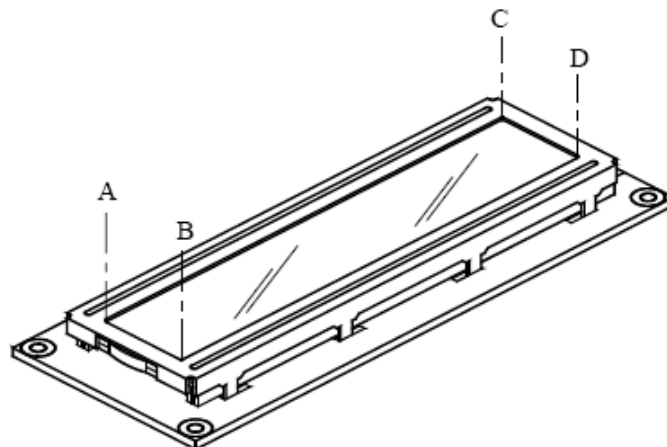

**4. ELECTRICAL CHARACTERISTICS**

(TA = 25 , Vss=0V)

Parameter	Applicable pins	Condition	MIN	TY P	MAX	Unit
Power supply voltage	VDD	-	4.5	5.0	5.5	V
“H” input voltage	VIH	-	VDD-0.2	-	VDD	V
“L” input voltage	VIL	-	0	-	0.8	V
“H” input voltage	VOH	-	VDD-0.3	-	VDD	V
“L” input voltage	VOL	-	0	-	0.3	V
“H” output resistor	ROH	VOUT=VDD-0.5	-	-	400	Ω
“L” output resistor	ROL	VOUT=0.5V	-	-	400	Ω
Input pull-up resistor	RPU	-	50	100	200	KΩ
Frequency	Fosc	-	0.4	-	5.5	MHz
Operating current	IDD(1)	VDD=5.0v f=3.0MHz	-	3.3	6.0	MA
Static current	IDD(2)	VDD=5.0V	-	-	3.0	UA



## 4.1 LED ELECTRICAL/OPTICAL CHARACTERISTICS

Item	Symbol	min	typ	max	Unit	Condition
Forward Voltage	V <sub>f</sub>	4.8	5.0	5.2	V	I <sub>f</sub> =200mA
Reverse Current	I <sub>r</sub>	-	200	-	uA	V <sub>r</sub> =5V
Dominant wave length	λ <sub>d</sub>	-	X=0.29 Y=0.30	-	nm	I <sub>f</sub> =200mA
Spectral Line Half width	Δλ	-	-	-	nm	I <sub>f</sub> =mA
Luminance	L <sub>v</sub>	-	120	-	cd/m <sup>2</sup>	I <sub>f</sub> =200mA

## 4.2 LED ABSOLUTE MAXIMUM RATINGS

Item	Symbol	Condition	Rating	Unit
Reverse Voltage	V <sub>r</sub>	T <sub>a</sub> =25℃	5	V
Absolute maximum forward current	I <sub>fm</sub>	T <sub>a</sub> =25℃	250	mA
Power description	pd	T <sub>a</sub> =25℃	1250	mW

### 4.2.1 LED ARRAY BLOCK DIAGRAM

(LED DICE 1×10= 10dices)

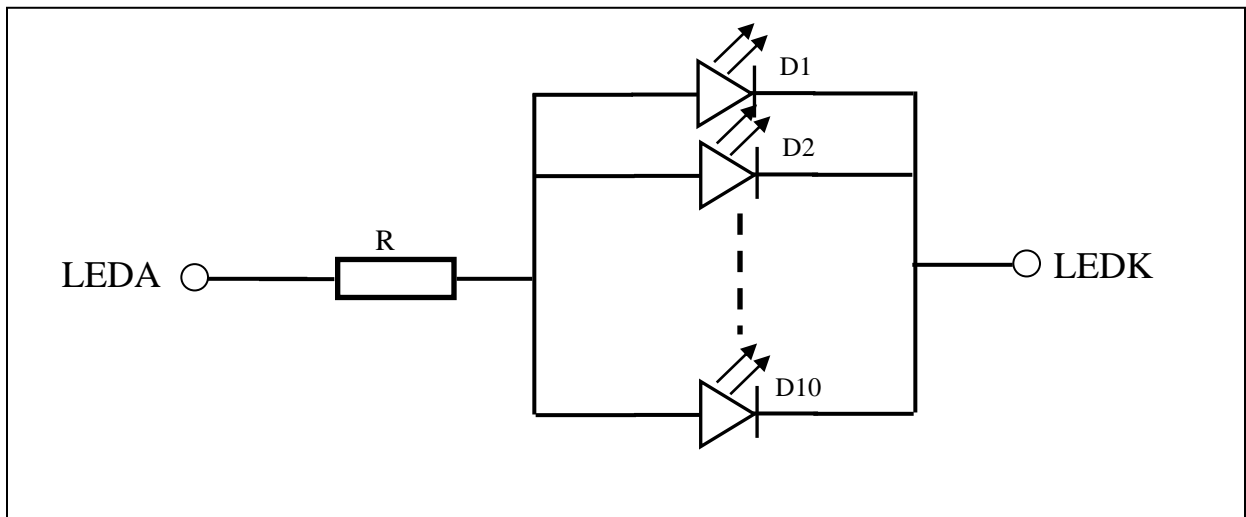

### 4.2.2 LED POWER SOURCE

LED	Option	Power source	Jumper setting
	A	A/K	R8-R11

# 5. ELECTRO-OPTICAL CHARACTERISTICS

ITEM	SYMBOL	CONDITION	MIN.	TYP.	MAX.	UNIT	NOTE
Contrast ratio	K	$\varphi=0$	1.4	4	-	-	1
Response time (rise)	$T_r$	$\varphi=0$	-	250	300	ms	2
Response time (fall)	$T_f$	$\varphi=0$	-	250	350	ms	2
Viewing angle	$\varphi$	$K \geq 2.0$	-40 -- +10			deg.	3
	$\theta$		-30 -- +30				

### Note 1: Definition of Contrast Ratio "K"

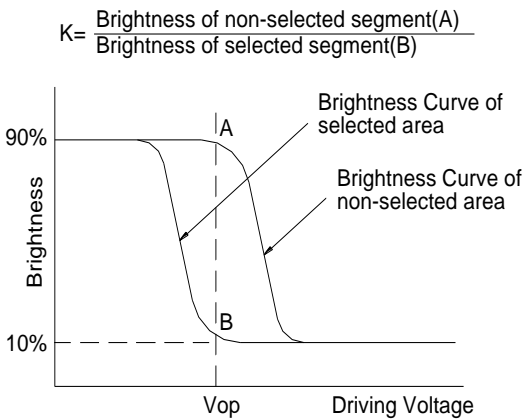

### Note 2: Definition of Optical Response Time

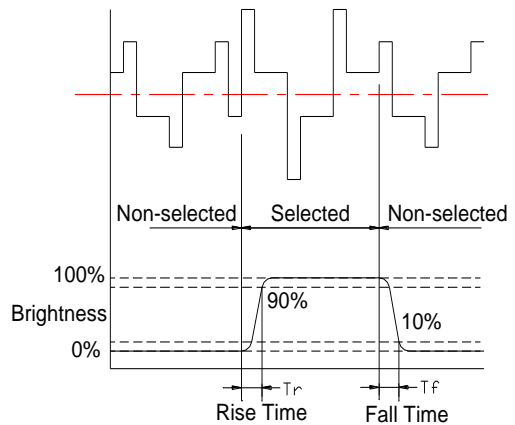

### Note 3: Definition of Viewing Angle

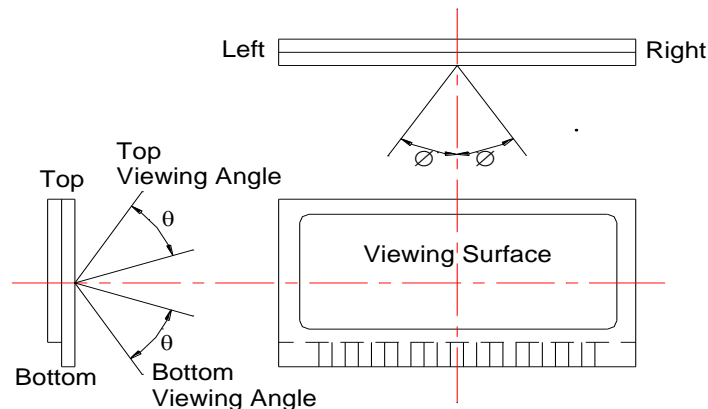

Please select either top or bottom viewing angle

## 6. BLOCK DIAGRAM

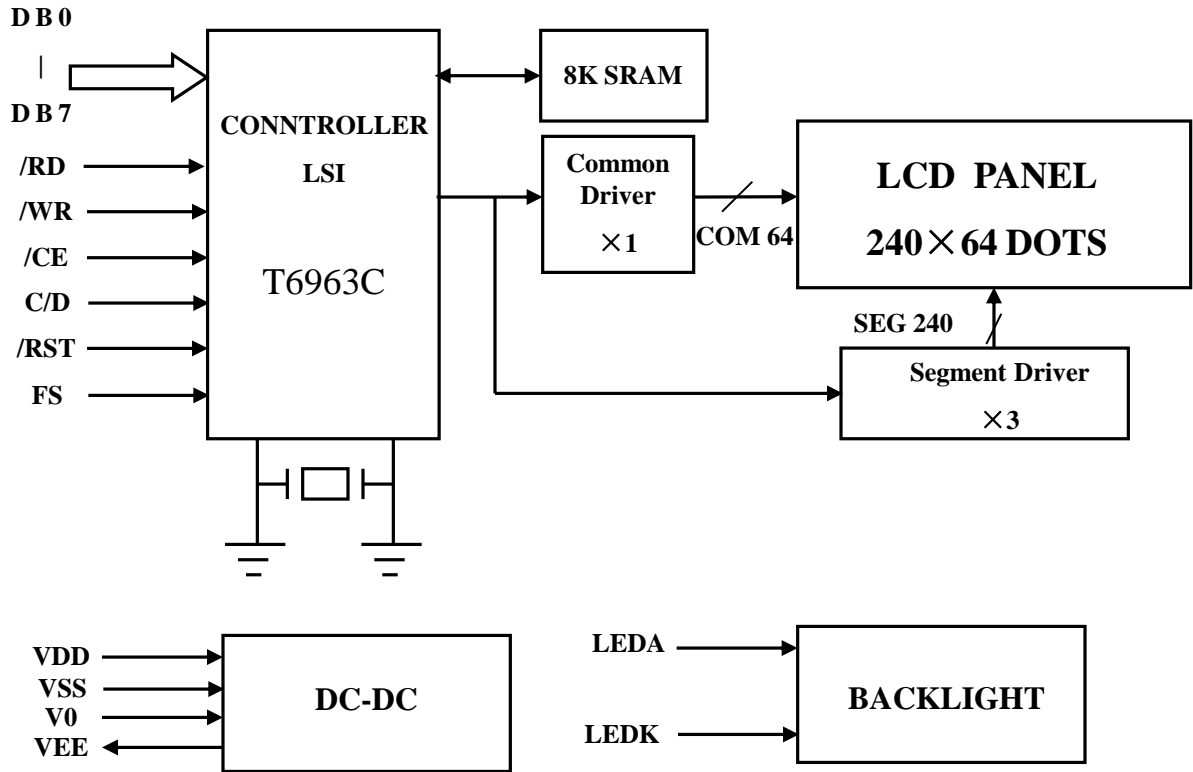

## 7. VOLTAGE REGULATOR CIRCUITS

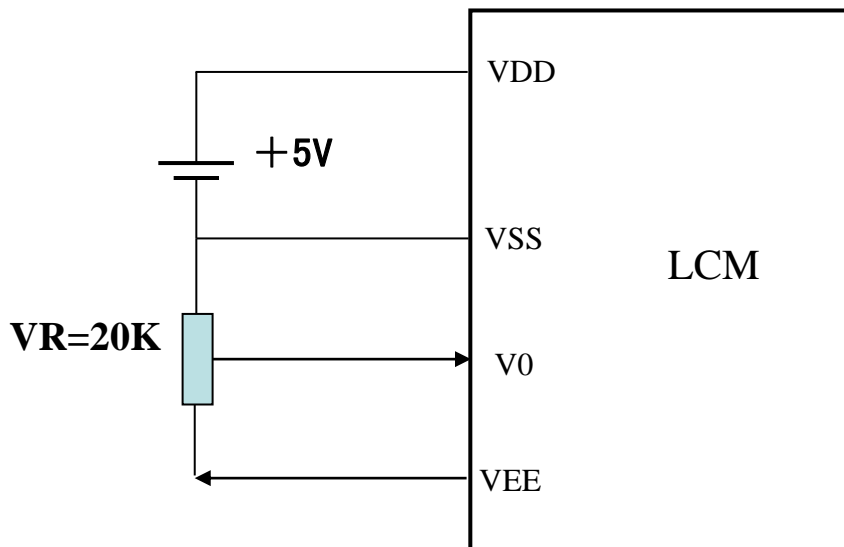

## 8. TIMING DIAGRAM

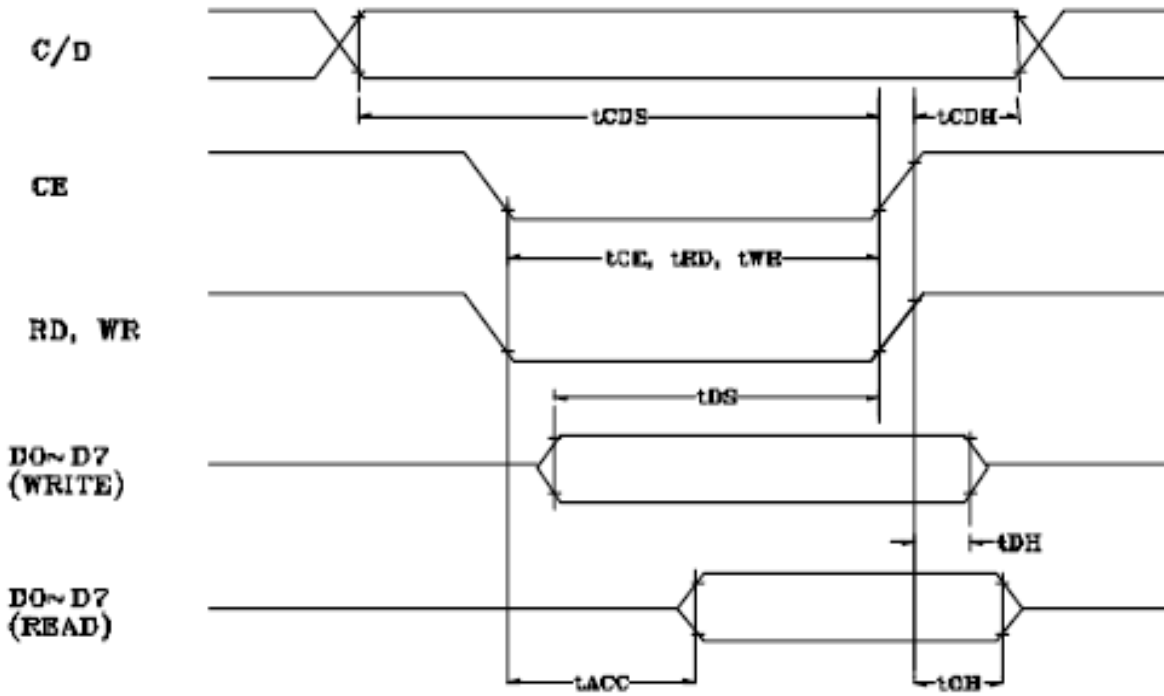

# 9. INSTRUCTION SET

Command	Code	D1	D2	Function
REGISTERS SETTING	00100001 00100010 00100100	X address Data Low address	Y address 00H High address	Set Cursor Pointer Set Offset Register Set Address Pointer
SET CONTROL WORD	01000000 01000001 01000010 01000011	Low address Columns Low address Columns	High address 00H High address 00H	Set Text Home Address Set Text Area Set Graphic Home Address Set Graphic Area
MODE SET	1000X000 1000X001 1000X011 1000X100 10000XXX 10001XXX	— — — — — —	— — — — — —	OR mode EXOR mode AND mode Text Attribute mode Internal CG ROM mode External CG RAM mode
DISPLAY MODE	10010000 1001XX10 1001XX11 100101XX 100110XX 100111XX	— — — — — —	— — — — — —	Display off Cursor on, blink off Cursor on, blink on Text on, graphic off Text off, graphic on Text on, graphic on
CURSOR PATTERN SELECT	10100000 10100001 10100010 10100011 10100100 10100101 10100110 10100111	— — — — — — — —	— — — — — — — —	1-line cursor 2-line cursor 3-line cursor 4-line cursor 5-line cursor 6-line cursor 7-line cursor 8-line cursor
DATA AUTO READ / WRITE	10110000 10110001 10110010	— — —	— — —	Set Data Auto Write Set Data Auto Read Auto Reset
DATA READ / WRITE	11000000 11000001 11000010 11000011 11000100 11000101	Data — Data — Data —	— — — — — —	Data Write and Increment ADP Data Read and Increment ADP Data Write and Decrement ADP Data Read and Decrement ADP Data Write and Nonvariable ADP Data Read and Nonvariable ADP
SCREEN PEEK	11100000	—	—	Screen Peek
SCREEN COPY	11101000			Screen Copy
BIT SET / RESET	11110XXX 11111XXX 1111X000 1111X001 1111X010 1111X011 1111X100 1111X101 1111X110 1111X111	— — — — — — — — — —	— — — — — — — — — —	Bit Reset Bit Set Bit 0 (LSB) Bit 1 Bit 2 Bit 3 Bit 4 Bit 5 Bit 6 Bit 7 (MSB)

# Y 10. STANDARD CHARACTER CODE TABLE

## CHARACTER CODE MAP

The relation between character codes and character pattern(CG TYPE 0101)

MSB \ LSB		Character Code															
		0	1	2	3	4	5	6	7	8	9	A	B	C	D	E	F
0			!	"	#	\$	%	&	'	(	)	*	+	,	-	.	/
1		0	1	2	3	4	5	6	7	8	9	:	;	<	=	>	?
2		A	B	C	D	E	F	G	H	I	J	K	L	M	N	O	
3		P	Q	R	S	T	U	V	W	X	Y	Z	[	\	]	^	_
4		`	a	b	c	d	e	f	g	h	i	j	k	l	m	n	o
5		p	q	r	s	t	u	v	w	x	y	z	{		}	~	
6		Q	Ü	Š	š	Ž	ž	Œ	œ	Ë	ë	İ	ı	İ	ı	Š	š
7		É	ë	Ë	š	š	ö	ü	ü	Ÿ	ö	ü	ø	æ	æ	Œ	f

# 11. QUALITY ASSURANCE

## 13.1.1 Temperature and Humidity(Ambient Temperature)

Temperature :  $20 \pm 5^{\circ} \text{C}$

Humidity :  $65 \pm 5\%$

## 13.1.2 Operation

Unless specified otherwise, test will be conducted under function state.

## 13.1.3 Container

Unless specified otherwise, vibration test will be conducted to the product itself without putting it in a container.

## 13.1.4 Test Frequency

In case of related to deterioration such as shock test.It will be conducted only once.

## 13.1.5 Test Method

No.	Parameter	Conditions	Regulations
1	High Temperature Operating	$70 \pm 2^{\circ} \text{C}$	Note 3
2	Low Temperature Operating	$-20 \pm 2^{\circ} \text{C}$	Note 3
3	High Temperature Storage	$80 \pm 2^{\circ} \text{C}$	Note 3
4	Low Temperature Storage	$-30 \pm 2^{\circ} \text{C}$	Note 3
5	Vibration Test (Non-operation state)	Total fixed amplitude : 1.5mm Vibration Frequency : 10 ~ 55Hz One cycle 60 seconds to 3 directions of X.Y.Z. for each 15 minutes	Note 3
6	Damp Proof Test (Non-operation state)	$40^{\circ} \text{C} \pm 2^{\circ} \text{C}$ , 90~95%RH, 96h	Note 1,2
7	Shock Test (Non-operation state)	To be measured after dropping from 60cm high once concrete surface in packing state	Note 3

Note 1: Returned under normal temperature and humidity for 4 hrs.

Note 2: No dew condensation to be observed.

Note 3: No change on display and in operation under the test condition

# 12. EXTERNAL DIMENSION

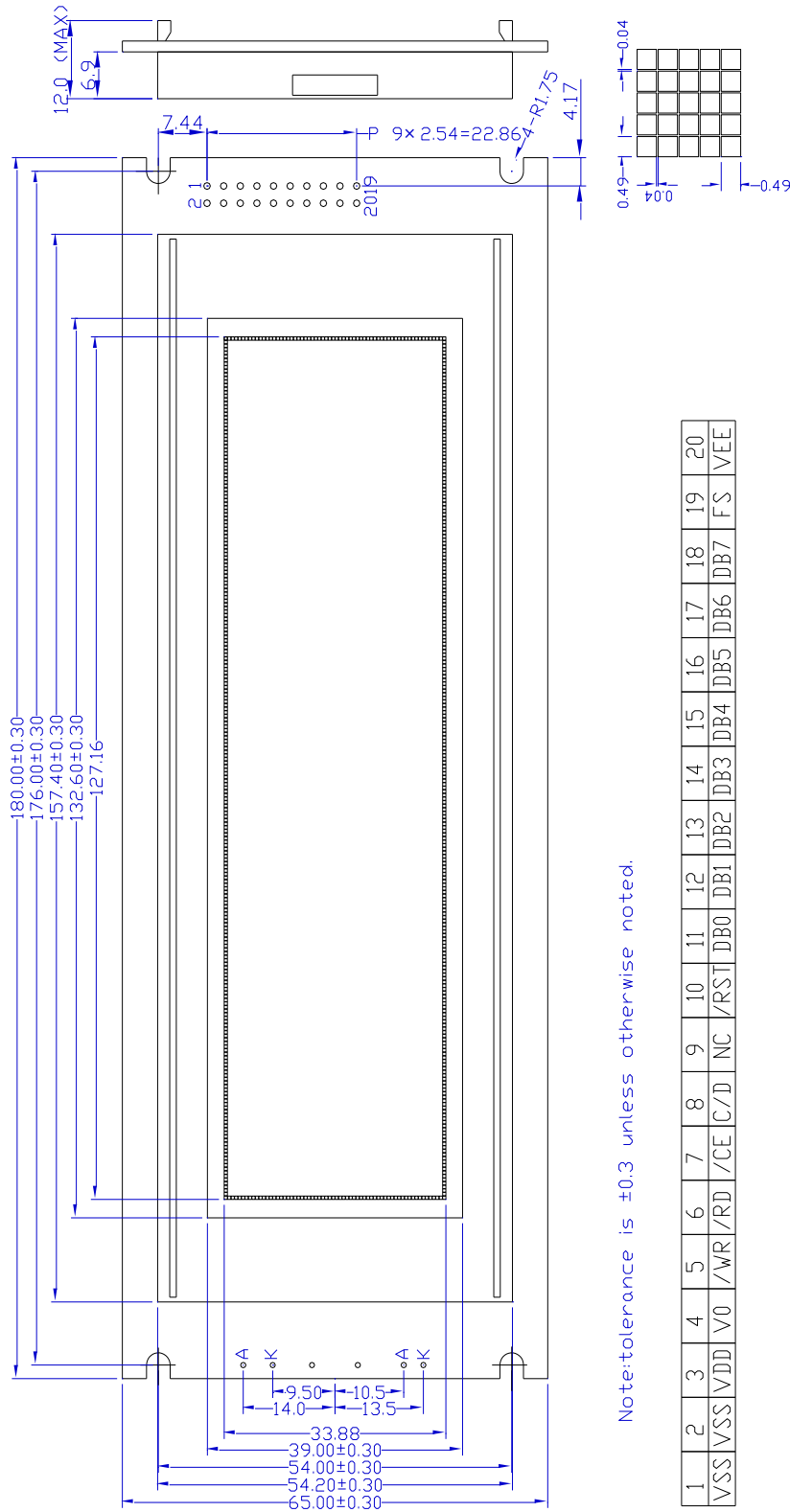



**13.INTERFACE**

PIN NO.	SYMBOL	DESCRIPTION	FUNCTION
1	VSS	GROUND	0V (GND)
2	VSS	GROUND	0V (GND)
3	VDD	POWER SUPPLY FOR LOGIC CIRCUIT	+5V
4	V0	LCD CONTRAST ADJUSTMENT	
5	/WR	WRITE SIGNAL	
6	/RD	READ SIGNAL	
7	/CE	CHIP SELECTION	CE=0:DATA AND INSTRUCTION ARE AVILABLE
8	C/D	INSTRUCTION/DATA REGISTER SELECTION	C/D=1:INSTRUCTION REGISTER C/D=0:DATA REGISTER
9	NC		
10	/RST	RESET SIGNAL	RST=0,DISPLAY OFF
11	DB0	DATA INPUT/OUTPUT LINES	8 BIT: DB0-DB7
12	DB1		
13	DB2		
14	DB3		
15	DB4		
16	DB5		
17	DB6		
18	DB7		
19	FS	FONT SELECTION	FS=0:8x8 FS=1:6x8
20	VEE	NEGATIVE VOLTAGE	-10V

A	LEDA	Power Supply For Led Backlight(A), +5V
K	LEDK	Power Supply For Led Backlight(K), GND

# 14. PACKAGE INFORMATION

A Box include 20pcs

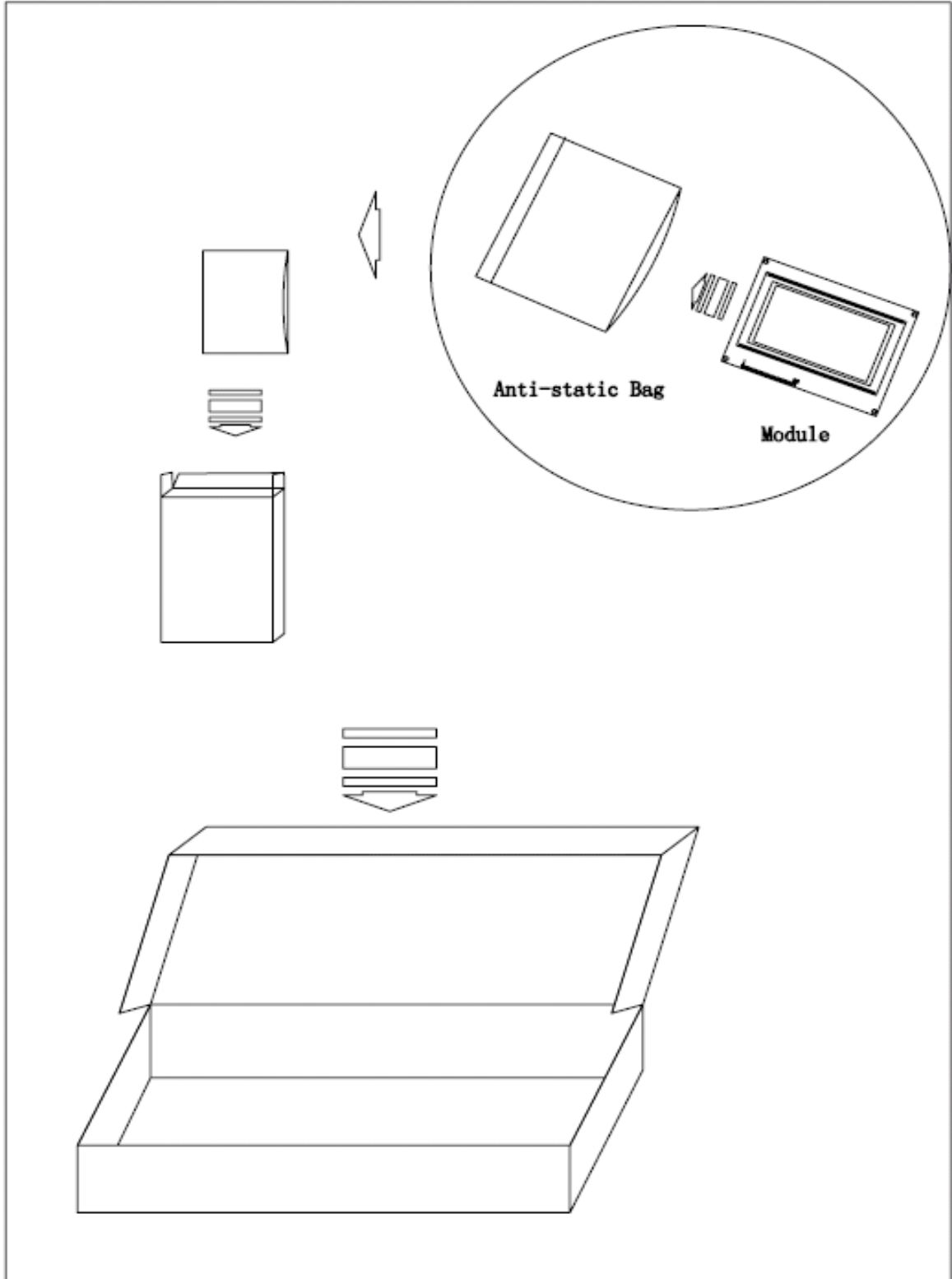

# 15. QC/QA PROCEDURE

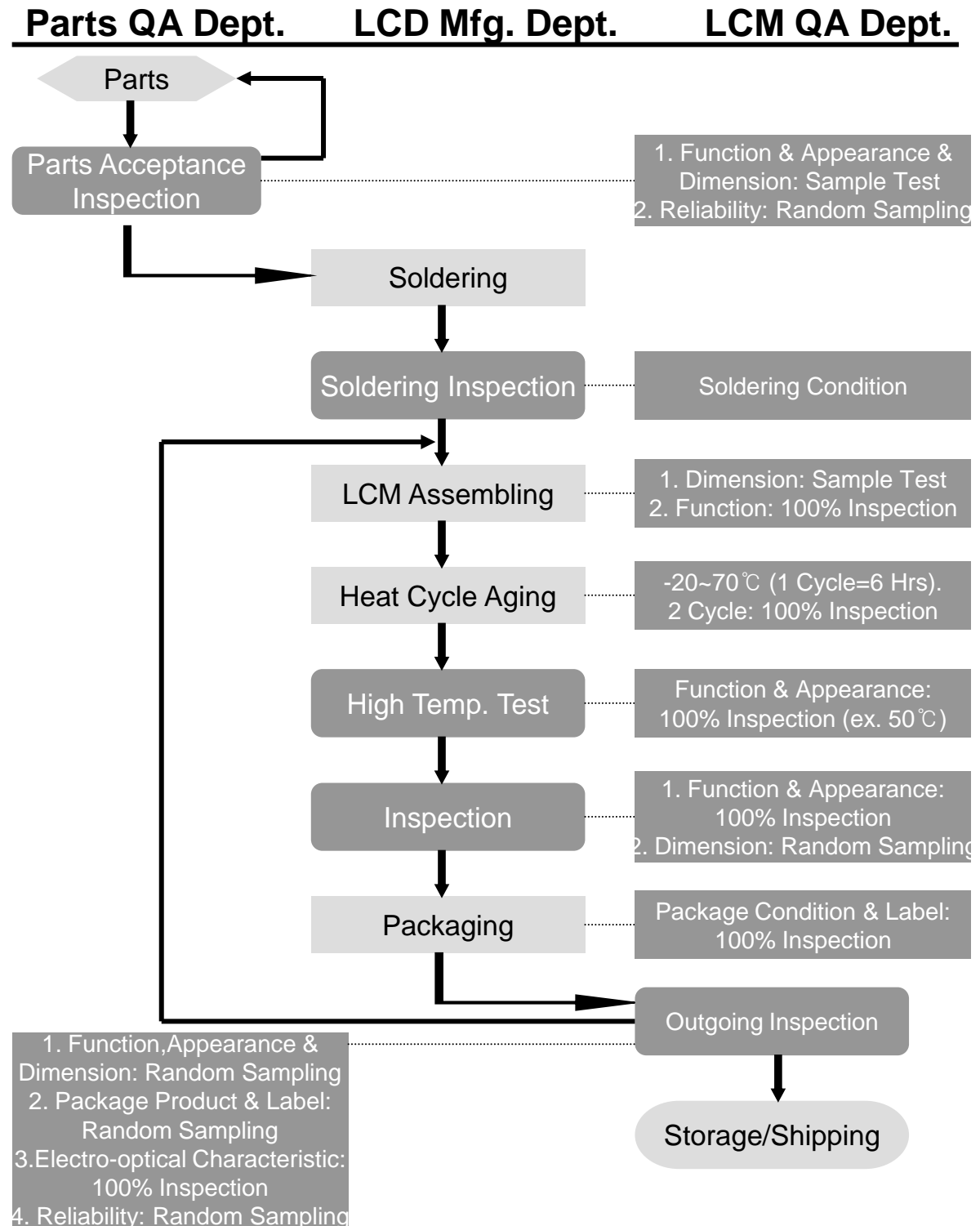

## 16. Handling Precaution

### 1. Limitation of Application:

Optrex products are designed for use in ordinary electronic devices such as business machines, telecommunications equipment, measurement devices and etc. Please handle the products with care. (see below)

Optrex products are not designed, intended, or authorized for use in any application which the failure of the product could result in a situation where personal injury or death may occur. these applications include, but are not limited to. life-sustaining equipment, nuclear control devices, aerospace equipment, devices related to hazardous or flammable materials, etc. [If Buyer intends to purchase or use the Optrex Products for such unintended or unauthorized applications, Buyer must secure prior written consent to such use by a responsible officer of Optrex Corporation.] Should Buyer purchase or use Optrex Products for any such unintended or unauthorized application [without such consent]. Buyer shall indemnify and hold Optrex and its officers, employees, subsidiaries, affiliates and distributors harmless against all claims, costs, damages and expenses, and reasonable attorney's fees, arising out of, directly or indirectly, any claim of personal injury or death associated with such unintended or unauthorized use, even if such claim alleges that Optrex was negligent regarding the design or manufacture of the part.

### 2. Industrial Rights and Patents

Optrex shall not be responsible for any infringement of industrial property rights of third parties in any country arising out of the application or use of Optrex products, except which directly concern the structure or production of such products.

### No Press and Shock!

If pressure to LCD, orientation may be disturbed.  
LCD will broken by shock!

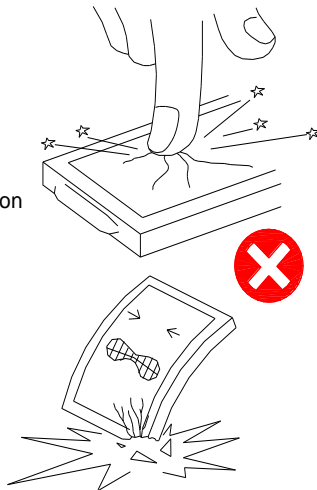

### Don't Swallow or Touch Liquid Crystal!

Liquid Crystal may be leaked when display is broke.  
If it accidentally gets your hands, wash then with water!

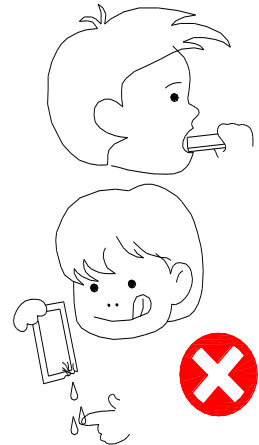

### Don't not Scratch!

Polarizer is a soft material and can easily be scratched.

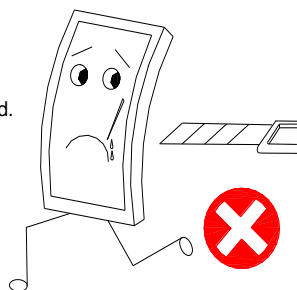

### No DC Voltage to LCD!

DC voltage or driving higher than the specified voltage will reduce the lifetime of the LCD.

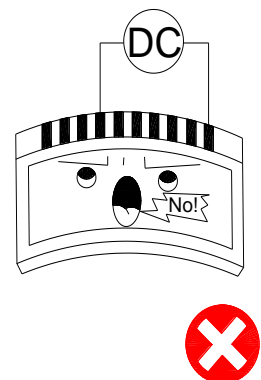

**Don't Press the Metallic Frame and Disassemble Slowly Peel Off Protective Film! the LCM**

Pressure on the metallic frame and PCB may deform the conductive rubber or break the liquid crystal cell and back light, which will cause defects.

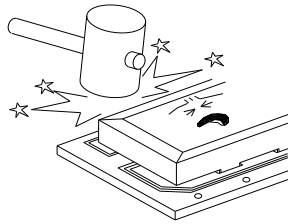

LCD may be shifted or conductive rubber may be reshaped, which will cause defects.

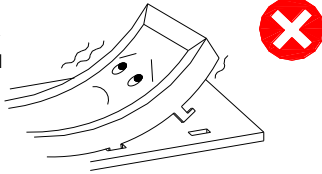

Avoid static electricity.

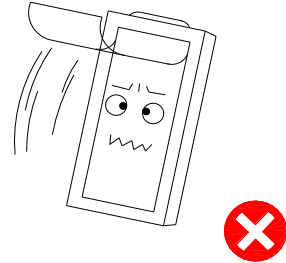

**Avoid Static Electricity!**

Please be sure to ground human body and electric appliances during work. It is preferable to use conductive mat on table and wear cotton clothes or conduction processed fiber. Synthetic fiber is not recommended.

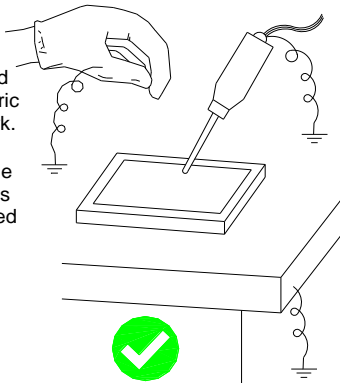

**Wear Gloves While Handling!**

It is preferable to wear gloves to avoid damaging the LCD.

Please do not touch electrodes with bare hands or make them dirty.

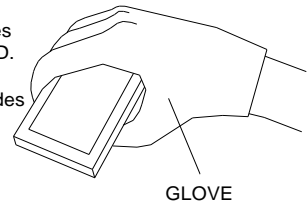

**Keep Away From Extreme Heat and Humidity!**

LCD deteriorates.

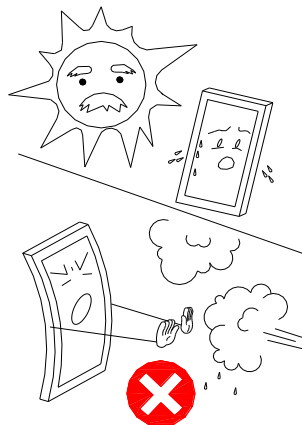

**Use Alcohol to Clean Terminals!**

When attaching with the heat seal or anisotropically conductive film, wipe off with alcohol before use.



### Don't Drop Water on LCD!

Note that the presence of waterdrops or dew in the LCD panel may deteriorate the polarizer or corrode electrode.

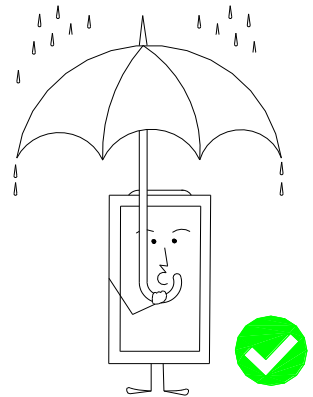

### Precaution in Soldering LCD Module

Basic instructions: Solder I/O terminals only.  
Use soldering iron without leakage.

#### (1) Soldering condition to I/O terminals

Temperature at tip of the iron:  $280 \pm 10^\circ\text{C}$

Soldering time: 3~4 sec.

Type of solder: Eutectic solder (containing colophony-flux)

\*Please do not use flux because it may soak into LCD Module or contaminate it.

\*It is preferable to peel off protective film on display surface after soldering I/O terminals is finished.

#### (2) Remove connector or cable

\*When you remove connector or cable soldered to I/O terminals, please confirm that solder is fully melted. If you remove by force, electrodes at I/O terminals may be damaged (or stripped off).

\*It is recommended to use solder suction machine.

### Long-term Storage

If it is necessary to store LCD modules for a long time, please comply with the following procedures.

If storage condition is not satisfactory, display (especially polarizer) may be deteriorated or soldering I/O terminals may become difficult (some oxide is generated at I/O terminals plating).

1. Store as delivered by Optrex

2. If you store as unpacked, put in anti-static bag, seal its opening and store where it is not subjected to direct sunshine nor fluorescent lamp.

3. Store at temperature  $0$  to  $+35^\circ\text{C}$  and at low humidity. Please refer to our specification sheets for storage temperature range and humidity condition.

### Long-term Storage

Please use power supply with built-in surge protection circuit.